

# RF and Microwave Power Amplifier and Transmitter Technologies — Part 4

By Frederick H. Raab, Peter Asbeck, Steve Cripps, Peter B. Kenington, Zoya B. Popovich, Nick Pothecary, John F. Sevic and Nathan O. Sokal

Linearization methods are the focus of Part 4 of our series on power amplifiers, which describes the basic architecture and performance capabilities of feedback, feedforward and predistortion techniques

Linearization techniques are incorporated into power amplifiers and transmitters for the dual purposes of improving linearity and for allowing operation with less back-off and therefore higher efficiency. This article provides

a summary of the three main families of techniques have been developed: Feedback, feedforward, and predistortion.

## 8a. FEEDBACK

Feedback linearization can be applied either directly around the RF amplifier (RF feedback) or indirectly upon the modulation (envelope, phase, or I and Q components).

### RF Feedback

The basis of this technique is similar to its audio-frequency counterpart. A portion of the RF-output signal from the amplifier is fed back to, and subtracted from, the RF-input signal without detection or down-conversion. Considerable care must be taken when using feedback at RF as the delays involved must be small to ensure stability. In addition, the loss of gain at RF is generally a more significant sacrifice than it is at audio frequencies. For these reasons, the use of RF feedback in discrete circuits is usually restricted to HF and lower VHF frequencies [99]. It can be applied within MMIC devices, however, well into the microwave region.

In an active RF feedback system, the voltage divider of a conventional passive-feedback system is replaced by an active (amplifier)

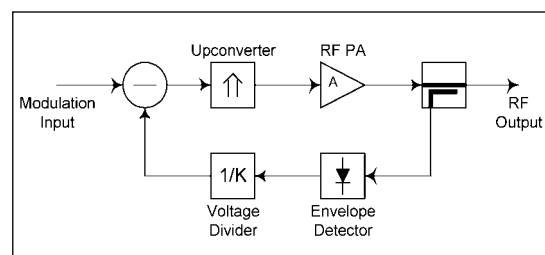

Fig 41 · Envelope feedback applied to a complete transmitter.

stage. The gain in the feedback path reduces the power dissipated in the feedback components. While such systems demonstrate IMD reduction [105], they tend to work best at a specific signal level.

### Envelope Feedback

The problem of delay in RF feedback is alleviated to a large extent by utilizing the signal envelope as the feedback parameter. This approach takes care of in-band distortion products associated with amplitude nonlinearity. Harmonic distortion products, which are corrected by RF feedback, are generally not an issue as they can easily be removed by filtering in most applications. Envelope feedback is therefore a popular and simple technique.

Envelope feedback can be applied to either a complete transmitter (Figure 41) or a single power amplifier (Figure 42). The principles of operation are similar and both are described in detail in [100]. The RF input signal is sampled by a coupler and the envelope of the input sample is detected. The resulting envelope is then fed to one input of a differential amplifier, which subtracts it from a similarly

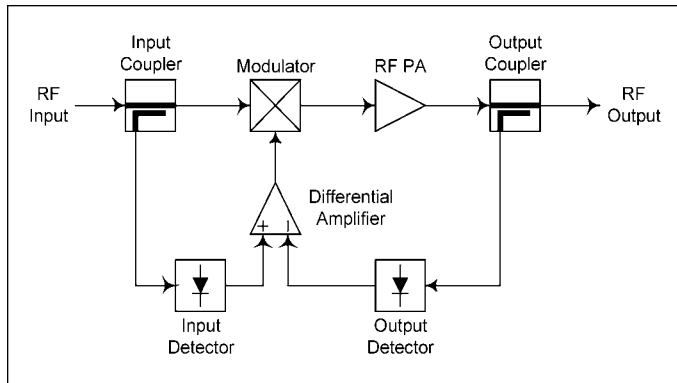

Figure 42 · Envelope feedback applied to an RF power amplifier.

obtained sample of the RF output. The difference signal, representing the error between the input and output envelopes, is used to drive a modulator in the main RF path. This modulator modifies the envelope of the RF signal which drives the RF PA. The envelope of the resulting output signal is therefore linearized to a degree determined by the loop gain of the feedback process. Examples of this type of system are reported in [101] and [102].

The degree of linearity improvement that can be obtained when using this technique depends upon the relative levels of the AM-AM and AM-PM conversion in the amplifier. For a VHF BJT amplifier, AM-AM distortion is dominant and two-tone IMD is typically reduced by 10 dB. Since AM-PM distortion is not corrected by envelope feedback, no linearity improvement is observed if phase distortion is the dominant form of nonlinearity. This is often the case in, for example, class-C and LDMOS PAs. The use of envelope feedback is therefore generally restricted to relatively linear class-A or AB amplifiers.

### Polar-Loop Feedback

The polar-loop technique overcomes the fundamental inability of envelope feedback to correct for AM-PM distortion effects [103]. Essentially, a phase-locked loop is added to the envelope feedback system as shown in Figure 43. For a narrowband VHF PA, the improvement in two-tone IMD is typically around 30 dB.

The envelope- and phase-feedback functions operate essentially independently. In this case, envelope detection occurs at the intermediate frequency (IF), as the input signal is assumed to be a modulated carrier at IF. Likewise, phase detection takes place at the IF, with limiting being used to minimize the effects of signal amplitude upon the detected phase. Alternatively, it is possible to supply the envelope and phase modulating signals separately at baseband and to undertake the comparisons there.

The key disadvantage of polar feedback lies in the gen-

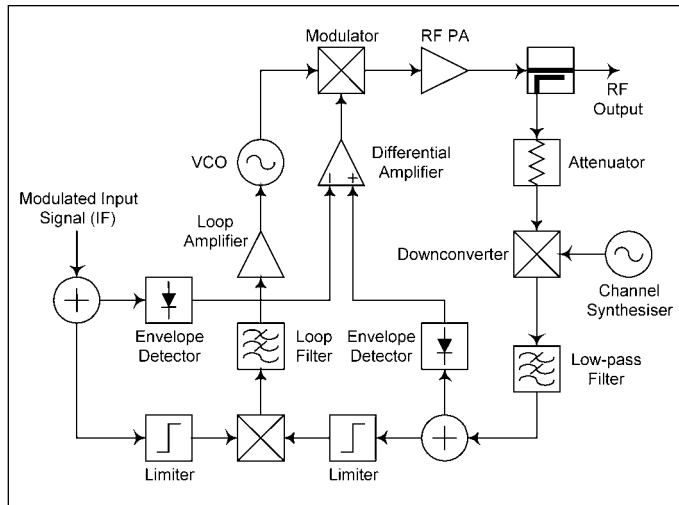

Figure 43 · Block diagram of a polar-loop transmitter.

erally different bandwidths required for the amplitude and phase feedback paths. Thus, differing levels of improvement of the AM-AM and AM-PM characteristics usually result, and this often leads to a poorer overall performance than that achievable from an equivalent Cartesian-loop transmitter. A good example of the difference occurs with a standard two-tone test, which causes the phase-feedback path to cope with a discontinuity at the envelope minima. In general, the phase bandwidth must be five to ten times the envelope bandwidth, which limits available loop gain for a given delay.

### Cartesian Feedback

The Cartesian-feedback technique overcomes the problems associated with the wide bandwidth of the signal phase by applying modulation feedback in I and Q (Cartesian) components [104]. Since the I and Q components are the natural outputs of a modern DSP, the Cartesian loop is widely used in PMR and SMR systems.

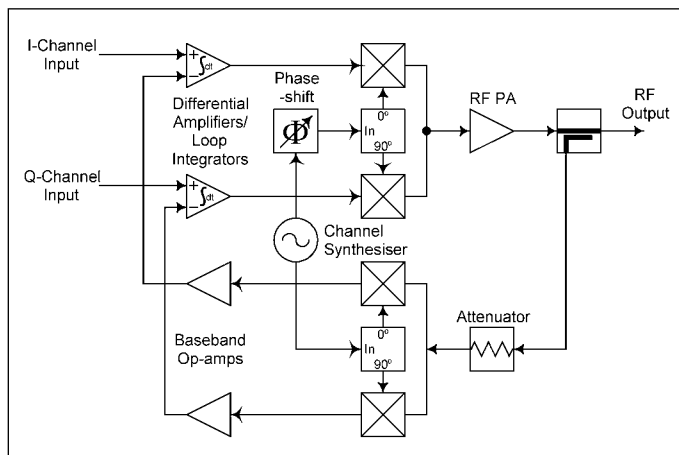

Figure 44 · Cartesian-loop transmitter configuration.

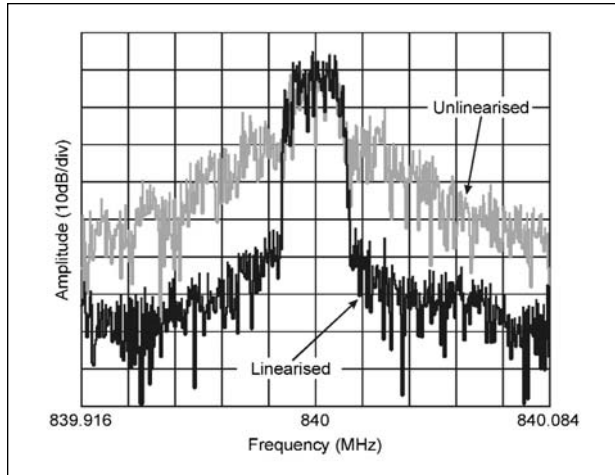

Figure 45 · Linearization of a class-C PA by Cartesian feedback (courtesy WSI).

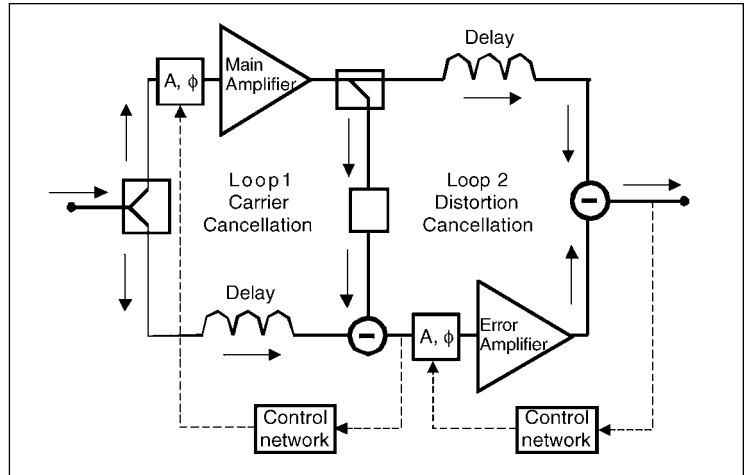

Figure 46 · Block diagram of a feed-forward transmitter in its basic form.

The basic Cartesian loop (Figure 44) consists of two identical feedback processes operating independently on the I and Q channels. The inputs are applied to differential integrators (in the case of a first-order loop) with the resulting difference (error) signals being modulated onto I and Q subcarriers and up-converted to drive the PA. A sample of the output from the PA is attenuated and quadrature-down-converted (synchronously with the up-conversion process). The resulting quadrature feedback signals then form the second inputs to the input differential integrators, completing the two feedback loops. The phase shifter shown in the up-converter local-oscillator path is used to align the phases of the up- and down-conversion processes, thereby ensuring that a negative feedback system is created and that the phase margin of the system is optimized.

The effects of applying Cartesian feedback to a highly nonlinear (class-C) PA amplifying an IS-136 (DAMPS) signal are shown in Figure 45. The first ACPR is improved by 35 dB and the signal is produced within specifications with an efficiency of 60 percent [100].

### 8b. FEEDFORWARD

The very wide bandwidths (10 to 100 MHz) required in multicarrier applications can render feedback and DSP impractical. In such cases, the feedforward technique can be used to achieve ultra-linear operation. In its basic configuration, feedforward typically gives improvements in distortion ranging from 20 to 40 dB.

#### Operation

In its basic form (Figure 46), a feedforward amplifier consists of two amplifiers (the main and error amplifiers), directional couplers, delay lines and loop control networks [110]. The directional couplers are used for power split-

ting/combining, and the delay lines ensure operation over a wide bandwidth. Loop-control networks, which consist of amplitude- and phase-shifting networks, maintain signal and distortion cancellation within the various feed-forward loops.

The input signal is first split into two paths, with one path going to the high-power main amplifier while the other signal path goes to a delay element. The output signal from the main amplifier contains both the desired signal and distortion. This signal is sampled and scaled using attenuators before being combined with the delayed portion of the input signal, which is regarded as distortion-free. The resulting “error signal” ideally contains only the distortion components in the output of the main amplifier. The error signal is then amplified by the low-power, high-linearity error amplifier, and then combined with a delayed version of the main amplifier output. This second combination ideally cancels the distortion components in the main-amplifier output while leaving the desired signal unaltered.

In practice, there is always some residual desired signal passing through the error amplifier. This is in general not a problem unless the additional power is sufficient in magnitude to degrade the linearity of the error amplifier and hence the linearity of the feedforward transmitter.

#### Signal Cancellation

Successful isolation of an error signal and the removal of distortion components depend upon precise signal cancellation over a band of frequencies. In practice, cancellation is achieved by the vector addition of signal voltages. The allowable amplitude and phase mismatches for different cancellation levels are shown in Figure 47. For manufactured equipment, realistic values of distortion

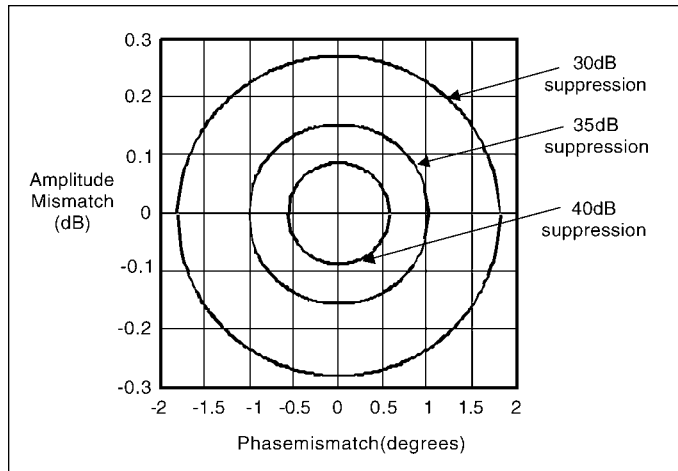

Figure 47 · Gain/phase matching requirements.

cancellation are around 25 to 30. The limiting factor is nearly always the bandwidth over which a given accuracy can be obtained.

### Efficiency

The outputs of the main and error amplifiers are typically combined in a directional coupler that both isolates the PAs from each other and provides resistive input impedances. For a typical 10 dB coupling ratio, 90 percent of the power from the main PA reaches the output. For the same coupling ratio, only 10 percent of the power from the error amplifier reaches the load, thus the error amplifier must produce ten times the power of the distortion in the main amplifier. The peak-to-average ratio of the error signal is often much higher than that of the desired signal, making amplification of the error signal inherently much less efficient than that of the main signal. As a result, the power consumed by the error amplifier can be a significant fraction (e.g., one third) of that of the main amplifier. In addition, it may be necessary to operate one or both amplifiers well into back-off to improve linearity. The overall average efficiency of a feedforward transmitter may therefore be only 10 to 15 percent for typical multi-carrier signals.

### Automatic Loop Control

Since feedforward is inherently an open-loop process,

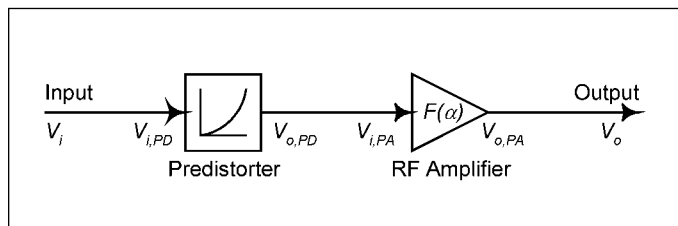

Figure 49 · Predistortion concept.

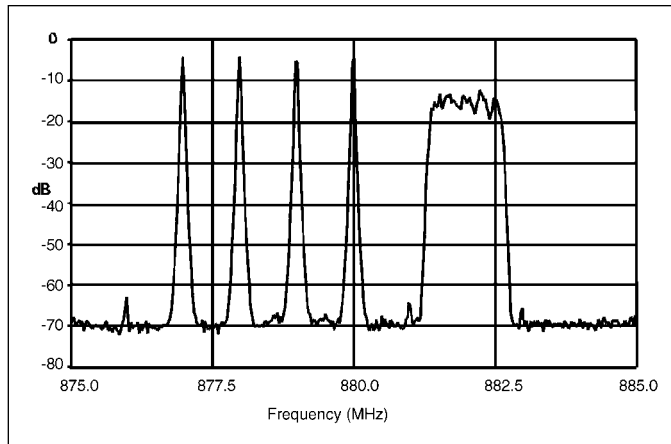

Figure 48 · Feedforward performance with mixed-mode modulation (TDMA and CDMA signals).

changes in device characteristics over time, temperature, voltage and signal level degrade the amplitude and phase matching and therefore increase distortion in the transmitter output. An automatic control scheme continuously adjusts the gain and phase to achieve the best signal cancellation and output linearity. The first step is to use FFT techniques, direct power measurement, or pilot signals to determine how well the loop is balanced. Both digital and analog techniques can be used for loop control and adjustment. Signal processing can be used to reduce the peaks in multi-carrier signals and to keep distortion products out of the nearby receiving band [111].

### Performance

An example of the use of feedforward to improve linearity is shown in Figure 48. The signal consists of a mix of TDMA and CDMA carriers. The power amplifiers are based upon LDMOS transistors and have two-tone IMD levels in the range  $-30$  to  $-35$  dBc at nominal output power. The addition of feedforward reduces the level of distortion by approximately 30 dB to meet the required levels of better than  $-60$  dBc. The average efficiency is typically about 10 percent.

### 8c. PREDISTORTION

The basic concept of a predistortion system (Figure 49) involves the insertion of a nonlinear element prior to the

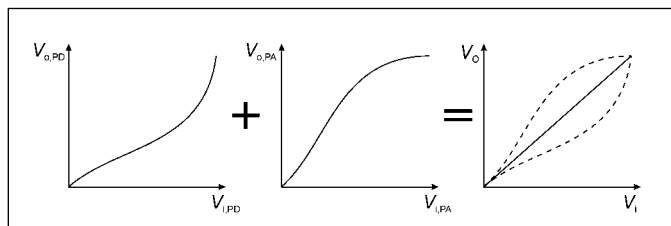

Figure 50 · Amplitude correction by predistortion.

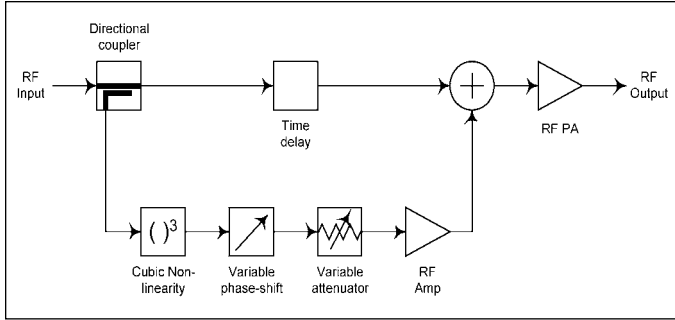

Figure 51 - An RF predistorter.

RF PA such that the combined transfer characteristic of both is linear (Figure 50). Predistortion can be accomplished at either RF or baseband.

**RF Predistortion**

The block diagram of a simple RF predistorter is shown in Figure 51. A compressive characteristic, created by the nonlinearity in the lower path (e.g., a diode) is subtracted from a linear characteristic (the upper path) to generate an expansive characteristic. The output of the linear path (typically just a time delay) is given by:

$$v_l(v_{in}) = a_1 v_{in} \tag{1}$$

and that of the compressive path is given by

$$v_c(v_{in}) = a_2 v_{in} - b v_{in}^3 \tag{2}$$

Subtracting the above equations gives

$$v_{pd}(v_{in}) = (a_2 - a_2) v_{in} - b v_{in}^3 \tag{3}$$

This is now an expansive characteristic with a linear gain of  $a_1 - a_2$ , and may be used to predistort a compressive amplifier characteristic (cubic in this example) by appropriate choice of  $a_1$ ,  $a_2$  and  $b$ .

An example of the results from using a simple diode-based RF predistorter with a 120-W LDMOS PA amplifying an IS-95 CDMA signal is shown Figure 52. When applied to  $\pi/4$ -DQPSK modulation in a satellite application, the same predistorter roughly halves the EVM, improves the efficiency from 22 to 29 percent, and doubles the available output power.

Predistortion bandwidths tend to be limited by similar factors to that of feedforward, namely gain and phase flatness of the predistorter itself and of the RF PA. In addition, memory effects in the PA and the predistorter limit the degree cancellation, and these tend to become poorer with increasing bandwidth.

Better performance can be achieved with more complex forms of RF predistortion such as Adaptive

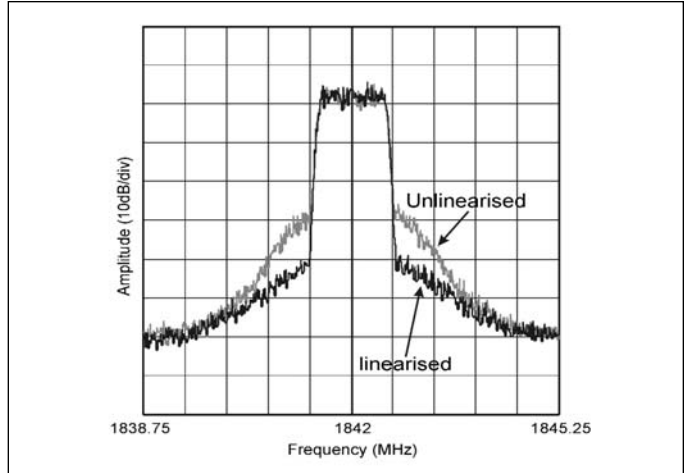

Figure 52 - Linearization by diode-based RF predistorter (courtesy WSI).

Parametric Linearization (APL<sup>®</sup>), which is capable of multi-order correction [106]. Most RF-predistortion techniques are capable of broadband operation with practical operational bandwidths similar to, or greater than, those of feedforward.

**Digital Predistortion**

Digital predistortion techniques exploit the considerable processing power now available from DSP devices, which allows them both to form and to update the required predistortion characteristic. They can operate with analog-baseband, digital-baseband, analog-IF, digital-IF, or analog-RF input signals. Digital-baseband and digital-IF processing are most common.

The two most common types of digital predistorter are termed mapping predistorters [107] and constant-gain

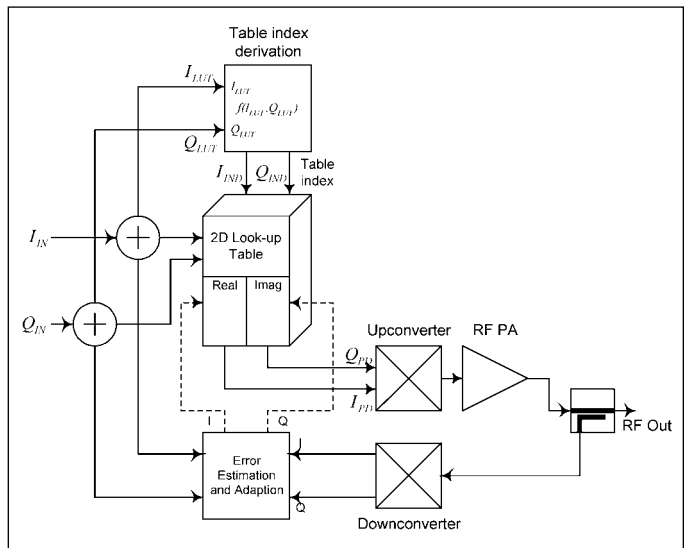

Figure 53 - Mapping predistorter.

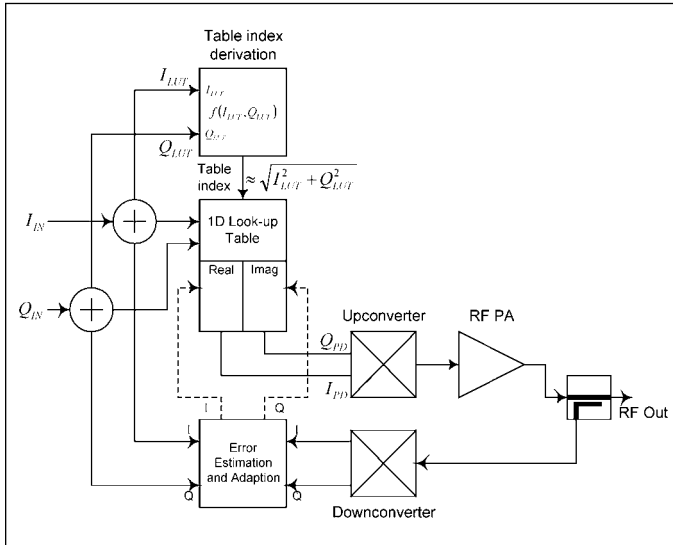

Figure 54 · Constant-gain predistorter.

predistorters [108]. A mapping predistorter utilizes two look-up tables, each of which is a function of two variables ( $I_{IN}$  and  $Q_{IN}$ ), as shown in Figure 53. This type of predistorter is capable of excellent performance. However, it requires a significant storage and/or processing overhead for the look-up tables and their updating mechanism, and has a low speed of convergence. The low convergence speed results from the need to address all points in the I/Q complex plane before convergence can be completed.

A constant-gain predistorter (Figure 54) requires only a single-dimensional look-up table, indexed by the signal envelope. It is therefore a much simpler implementation and requires significantly less memory for a given level of performance and adaptation time. It uses the look-up table to force the predistorter and associated PA to exhibit a constant gain and phase at all envelope levels. The

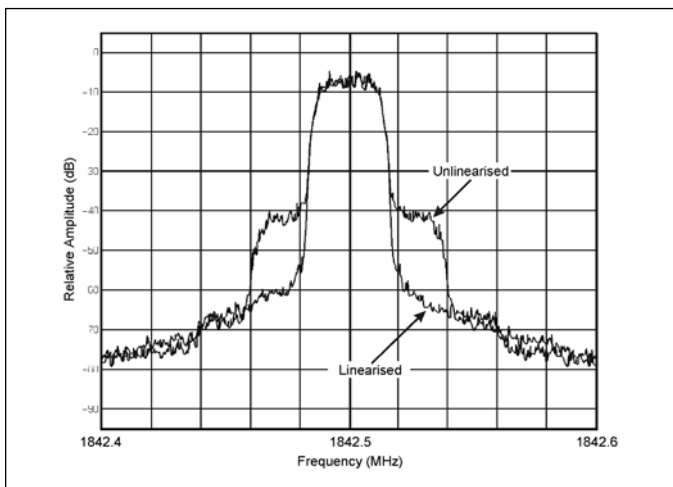

Figure 56 · Linearization of DAMPS PA by RF input/output predistorter (courtesy WSI).

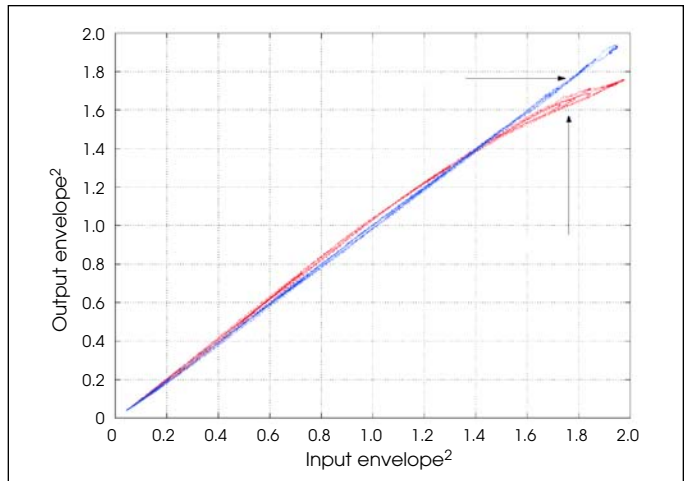

Figure 55 · Linearization of the amplitude transfer characteristic using an RF input/output digital predistorter (courtesy WSI).

overall transfer characteristic is then linear:

$$G_{PD}(I_{IN}(t), Q_{IN}(t)) \times G_{PA}(I_{PD}(t), Q_{PD}(t)) = k \quad (4)$$

An example of the improvement in the amplitude-transfer characteristic by an RF-input/output digital predistorter [109] is shown in Figure 55. The plot is based upon real-time using samples from a GSM-EDGE signal. Both the gain expansion and compression are improved by the linearizer. EVM is reduced from around 4.5 to 0.7 percent. The ACPR for IS-136 DAMPS modulation ( $\pi/4$ -DQPSK) is reduced by nearly 20 dB (Figure 56). When generating mask-compliant EDGE modulation at full output power (850-900 MHz), the linearized PA has an efficiency of over 30 percent.

An example of linearization of a PA with two 3G W-

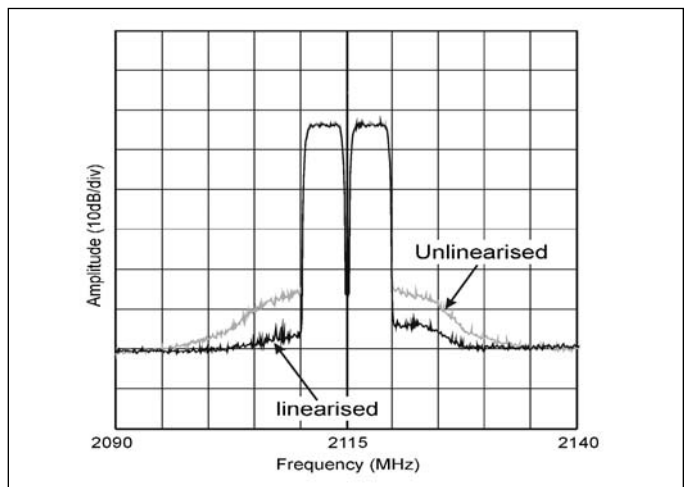

Figure 57 · Linearization of 3G W-CDMA PA signal by digital baseband input predistorter (courtesy WSI).



Figure 58 · A multi-carrier S-band transmitter with digital predistorter (courtesy WSI).

CDMA signals by a digital baseband-input predistorter is shown in Figure 57. The linearized amplifier meets the required spectral mask with a comfortable margin at all frequency offsets. The noise floor is set by the degree of clipping employed on the waveform, which limits the ACPR improvement obtained. It clearly demonstrates, however, that digital predistortion can be used in broadband as well as narrowband applications. Figure 58 shows a 3G transmitter that uses digital predistortion.

## References

99. A. F. Mitchell, "A 135 MHz feedback amplifier," *IEE Colloq. Broadband High Frequency Amplifiers: Practice and Theory*, pp. 2/1-2/6, London, Nov. 22, 1979
100. P. B. Kenington, *High Linearity RF Amplifier Design*, Norwood, MA: Artech, 2000.
101. W. B. Bruene, "Distortion reducing means for single-sidedband transmitters," *Proc. IRE*, vol. 44, no. 12, pp. 1760-1765, Dec. 1956.
102. T. Arthanayake and H. B. Wood, "Linear amplification using envelope feedback," *Electronics Letters*, vol. 7, no. 7, pp. 145-146, April 8, 1971.
103. V. Petrovic and W. Gosling, "Polar-loop transmitter," *Electronics Letters*, vol. 15, no. 10, pp. 286-287, May 10, 1979.

104. V. Petrovic, "Reduction of spurious emission from radio transmitters by means of modulation feedback," *Proc. IEE Conf. No. 224 on Radio Spectrum Conservation Techniques*, UK., Sept. 6-8 1983.

105. E. Ballesteros, F. Perez, and J. Peres, "Analysis and design of microwave linearized amplifiers using active feedback," *IEEE Trans. Microwave Theory Tech.*, vol. 36, no. 3, pp. 499-504, March 1988.

106. P. B. Kenington, "Achieving high-efficiency in multi-carrier base-station power amplifiers," *Microwave Engr. Europe*, pp. 83-90, Sept. 1999.

107. Y. Nagata, "Linear amplification techniques for digital mobile communications," *Proc. IEEE Veh. Tech. Conf. (VTC '89)*, San Fransisco, pp. 159-164, May 1-3, 1989.

108. J. K. Cavers, "Amplifier linearisation using a digital predistorter with fast adaptation and low memory requirements," *IEEE Trans. Veh. Tech.*, vol. 39, no. 4, pp. 374-382, Nov. 1990.

109. P. B. Kenington, M. Cope, R. M. Bennett, and J. Bishop, "GSM-EDGE high power amplifier utilising digital linearisation," *IMS'01 Digest*, Phoenix, AZ, May 20-25, 2001.

110. N. Potheary, *Feedforward Linear Power Amplifiers*, Norwood, MA: Artech, 1999.

111. J. Tellado, *Multicarrier Modulation with Low PAR*, Boston: Kluwer, 2000.

## Author Information

The authors of this series of articles are: Frederick H. Raab (lead author), Green Mountain Radio Research, e-mail: f.raab@ieee.org; Peter Asbeck, University of California at San Diego; Steve Cripps, Hywave Associates; Peter B. Kenington, Andrew Corporation; Zoya B. Popovic, University of Colorado; Nick Potheary, Consultant; John F. Sevic, California Eastern Laboratories; and Nathan O. Sokal, Design Automation. Readers desiring more information should contact the lead author.

## Acronyms Used in Part 4

ACPR	Adjacent Channel Power Ratio
APL	Adaptive Parametric Linearization
BER	Bit Error Rate
DAMPS	Digital American Mobile Phone System
EDGE	Enhanced Data for GSM Evolution
EVM	Error Vector Magnitude
IF	Intermediate Frequency
LDMOS	Laterally Diffused Metal Oxide Semiconductor
PA	Power Amplifier
PDF	Probability-Density Function
PMR	Private Mobile Radio
SMR	Specialized Mobile Radio
W-CDMA	Wideband Code-Division Multiple Access